

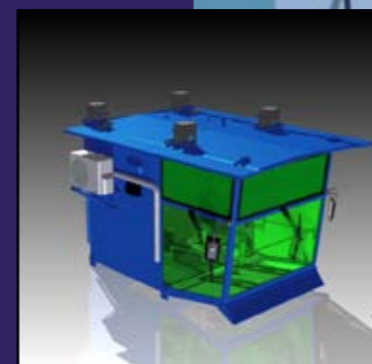

MERFORD

RTG cab

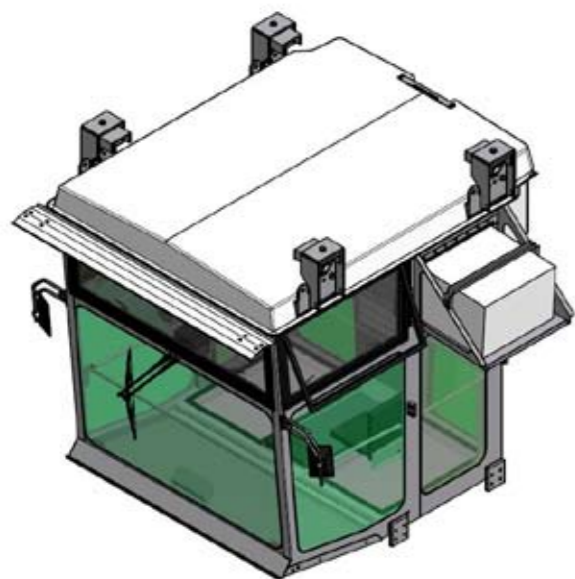
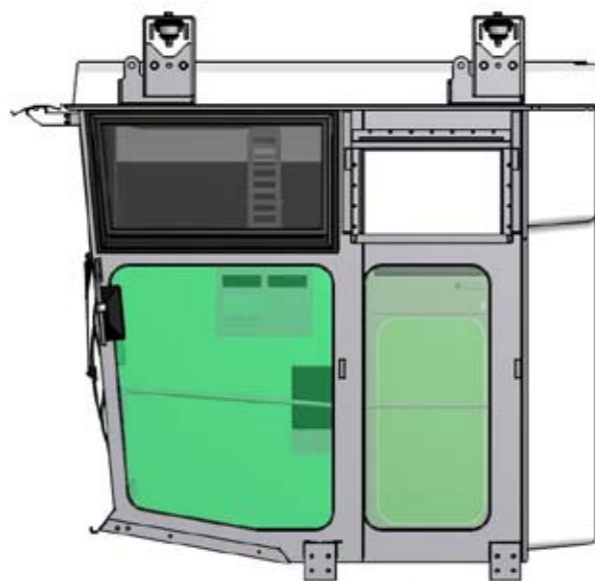
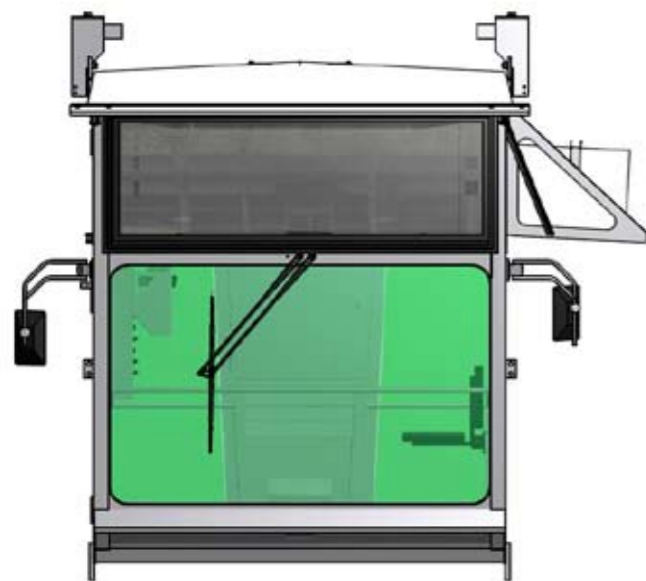

Merford Cabins BV
Web address: www.ergocab.com
E-mail: ergocab@merford.nl
Phone: +31 184 606000
Fax: +31 184 602794
Country: The Netherlands

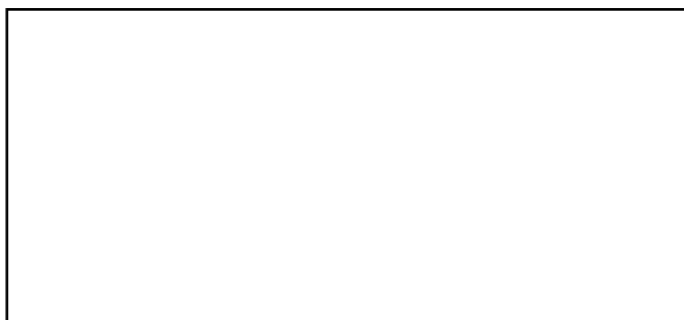

Innovation
Health and safety
Efficiency

RTG Operator Cab

Many container crane operators suffer from back and neck problems. The typical problems a RTG driver faces are highly underestimated. Looking around while driving the machine and looking sideways and under beams while searching for trucks leads to difficult postures.

Merford designed a specific cab for RTG cranes to create an optimum working environment.

This cab provides a healthy and safe working place. It features optimal visibility, comfort regarding noise and vibrations, and ergonomics for the operator.

www.ergocab.com

In combination with our Ergoseat or BalanSeat this cab offers the best solution for an optimum working environment. This improves the well being and performance of the operator and the efficiency of the crane.

Scientific research has proven that these seats prevent and reduce lower back pain and fatigue when sitting for prolonged periods of time.

Several parts of the cab are made of fibreglass. The fibreglass makes the cab less heavy, has a longer lifespan and will be more cost efficient.

These cabs are a result of 40 years experience in producing crane cabs, our contacts with container terminals world wide and scientific research.



Specification		Cabin			
		Ecocab	RTG cabin	STS cabin	
Dimensions	LxWxH: approx. 3400 x 2100 x 2500mm	X	X	S	
	LxWxH: approx. 3600 x 2100 x 2500mm	X	X	O	
	LxWxH: approx. 2500 x 2000 x 2500mm	X	S	X	
	LxWxH: approx. 2050 x 1600 x 2300mm	S	X	X	
	LxWxH: approx. 2400 x 1600 x 2300mm	O	X	X	
Construction	Single skinned	S	X	X	
	Double skinned	X	S	S	
	Roof mounted	O	S	S	
	Floor mounted	S	X	O	
Insulation	40mm Akusticell	S	X	X	
	50mm Rock wool	X	S	S	
Floor	Double construction with room for electrical cabling	S	S	S	
	Anti slip surface	S	S	S	
Roof	Double construction with room for electrical cabling	X	S	S	
	Drip rails	S	X	X	
	Rain gutters	X	S	S	
	4 Lifting lugs	S	S	S	
Ceiling	40mm Akusticell	S	X	X	
	Perforated steel panels for integration of accessoires.	X	S	S	
Cable entry	In floor	S	S	S	
	In wall	O	O	O	
	In roof	O	O	O	
Windows	Single glazed windows	S	S	S	
	Double glazed windows	O	O	O	
	Hinged upper front window	X	O	O	
	Hinged upper side windows	X	O	O	
	Sliding upper front window	O	O	O	
	Sliding upper side windows	O	O	O	
	Hinged floor window	X	O	O	
	Heated windows	X	O	O	
	Rytec clear shield	X	S	S	
	Climate-control	Heating demisting system	O	S	S
Filter overpressure system		X	O	S	
Automatic climat control system		X	X	O	
Airconditioning window unit		O	X	X	
Airconditioning split type unit		X	O	O	
Control units	Airconditioning roof top unit	O	X	X	
	Operator seat type Basic	O	O	O	
	Operator seat type Standard	O	O	O	
	Operator seat type Heavy duty	O	O	O	
	Ergoseat-S	O	O	O	
	Ergoseat-H	X	S	S	
	BalanSeat	X	O	O	
	Accessoires	Interior lighting and switch	S	S	S
		Window wipers	O	O	O
		Rolling sunblinds	O	O	O
Electrical cabinet		O	S	S	
Trainers seat		O	O	O	
Personal locker		O	O	S	
Rear view mirrors		O	O	O	
Fun radio		O	O	O	
Fire extinguisher		O	O	O	
Camera system		O	O	O	
Other Accessoires	On request	On request	On request		
Electrical equipment	On request	On request	On request		